

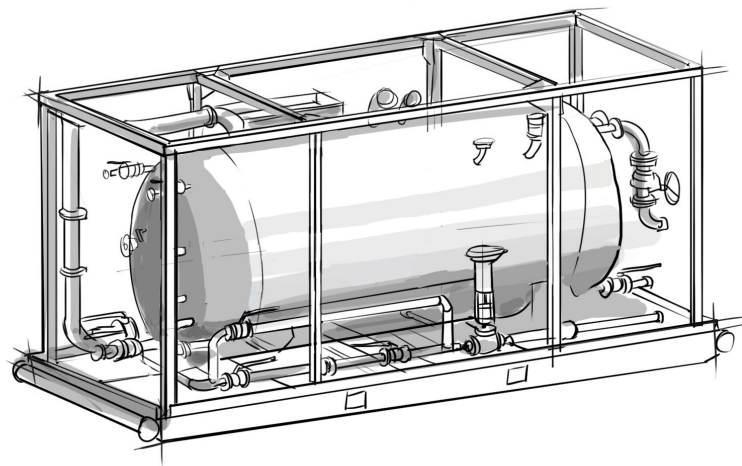

Well Testing

LP - 600 Series Super Separators

LP - 600 Series Super Separators are designed for a low pressure application in which a high retention time is required. The separators are used to separate well effluent into three main constituents: oil, water and gas.



Technical Specifications

Equipment	LP - 600
Vessel Size	84" O.D. x 12'
Skid Dimensions (L x W x H)	22'5" x 8'6" x 10'1"
Tare Weight (lbs.)	26,200
Operating Weight (lbs.)	55,100
M.A.W.P. (psi)	230
Maximum Temperature (°F)	200
Minimum Temperature (°F)	-20
Inlet	4" 206
Gas Outlet	3" 206
Oil Outlet	3" 206
Water Outlet	3" 206
PSV Outlet	4" 206
Deck Load Capacity (lbs./ft²)	290
NACE MR 0175	Yes
Series Design Code	ASME Sec VIII Div. 1, ASME B 31.3, ASME Sec IX

