



Water Treatment

Variable Frequency Drive Technology

Electric Pumps

The Variable Frequency Drive (VFD) package adds to traditional pumping methods by incorporating automatic or manual variable flow control. The VFD package is more efficient than diesel-powered counterparts and includes a VFD control panel, 30 HP or 50 HP electric pump and an optional automated level control system.

Features & Benefits

- UL 508 certified
- Energy efficient
- No pump emissions
- Less maintenance and repairs than fixed speed pumps
- Variable speed control
- Smaller footprint than traditional pump skids
- Air-cooled VFD panel
- Reduced noise levels
- Attached purge system

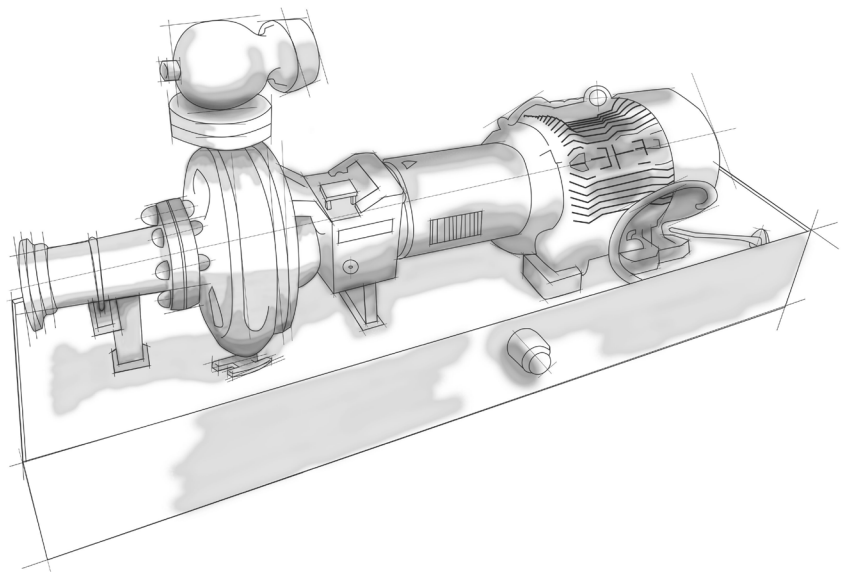

Technical Specifications

Equipment	Dimensions (L x W x H)	Weight (lbs.)	Power In	Power Out
VFD - Electric Pumps	5'4" x 3'4" x 8'5"	1,255 and 2,000	480 V and 30 kW	0 - 60 Hz

